

InfiniGen: Efficient Generative Inference of Large Language Models with Dynamic KV Cache Management

Wonbeom Lee*, Jungi Lee*, Junghwan Seo, Jaewoong Sim
Seoul National University

Motivation

LLM Inference & KV Cache

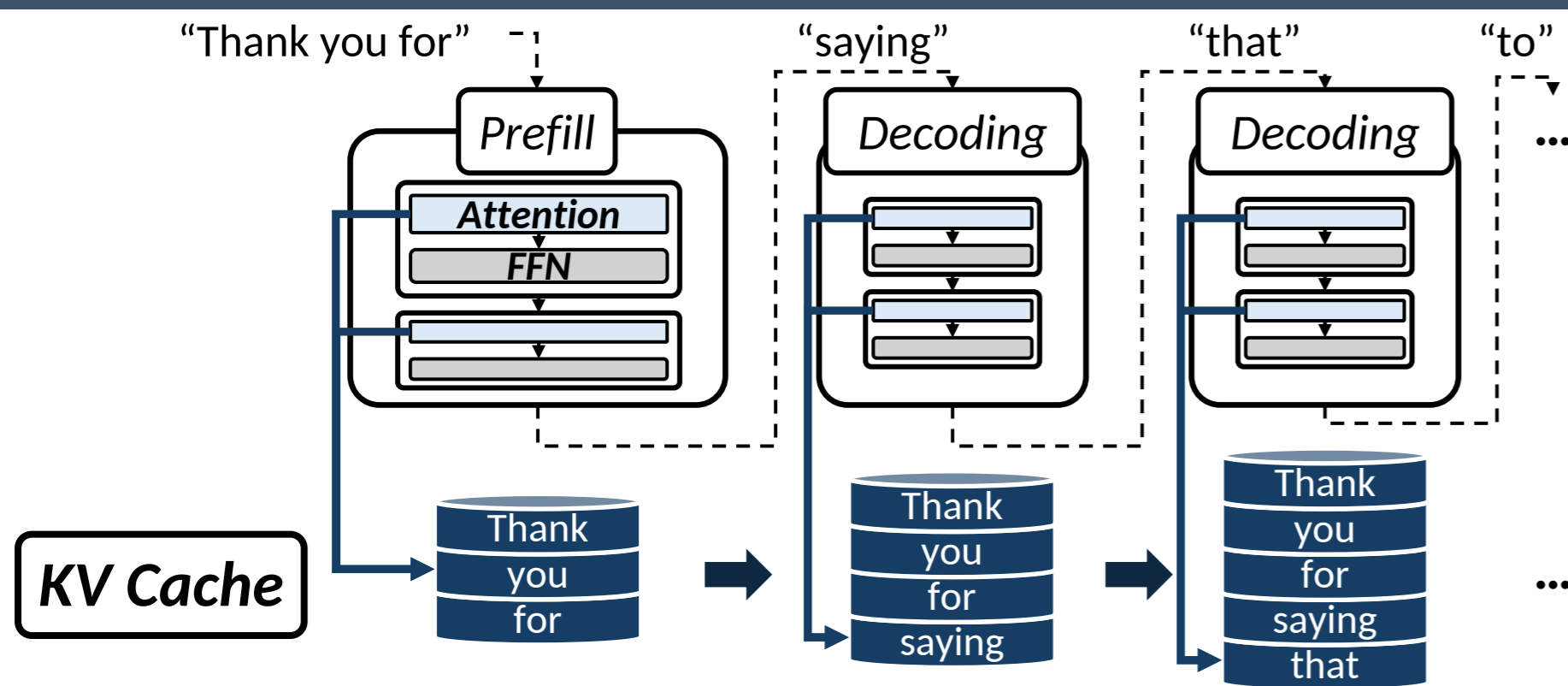

LLMs **memoize** the keys and values of the preceding tokens in memory to generate a new token that aligns well with the context.

KV Cache Size & Transfer Overhead

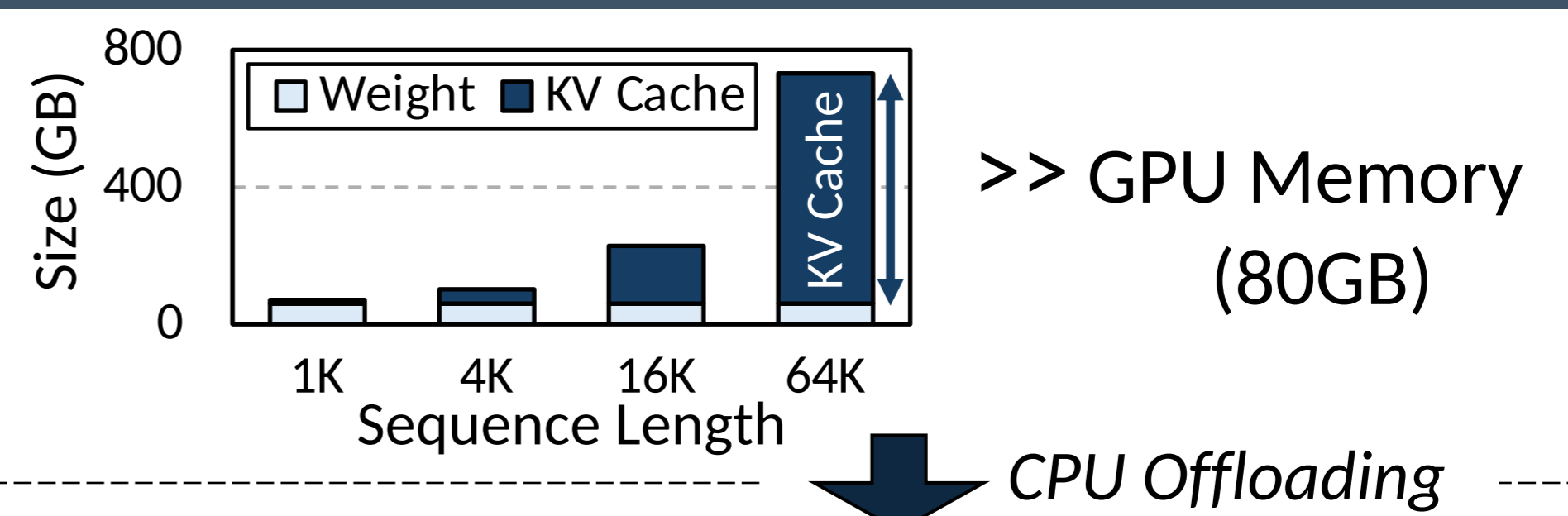

Offloading can enable longer sequences exploiting large CPU memory, but lead to a **significant slowdown** due to the **limited PCIe bandwidth**.

Challenges

Dynamic Nature of Attention Patterns across Iterations

Prior approaches **permanently evict** unimportant tokens.

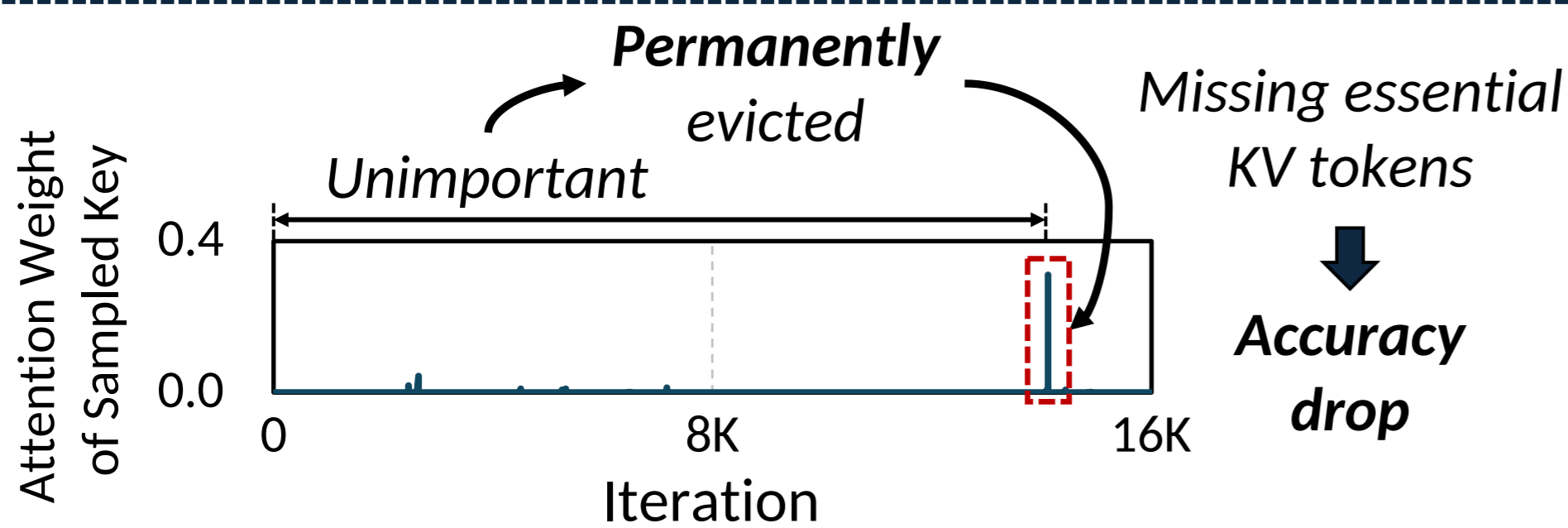

Adjusting the Number of KV across Layers and Queries

Prior approaches use a **fixed KV cache size budget**.

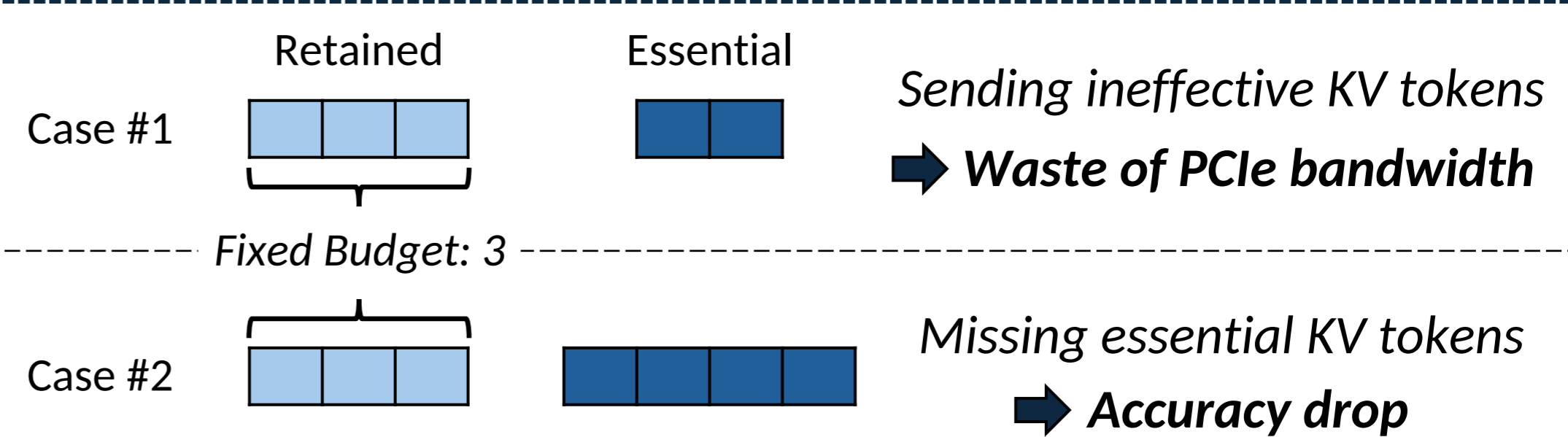

InfiniGen

InfiniGen Design

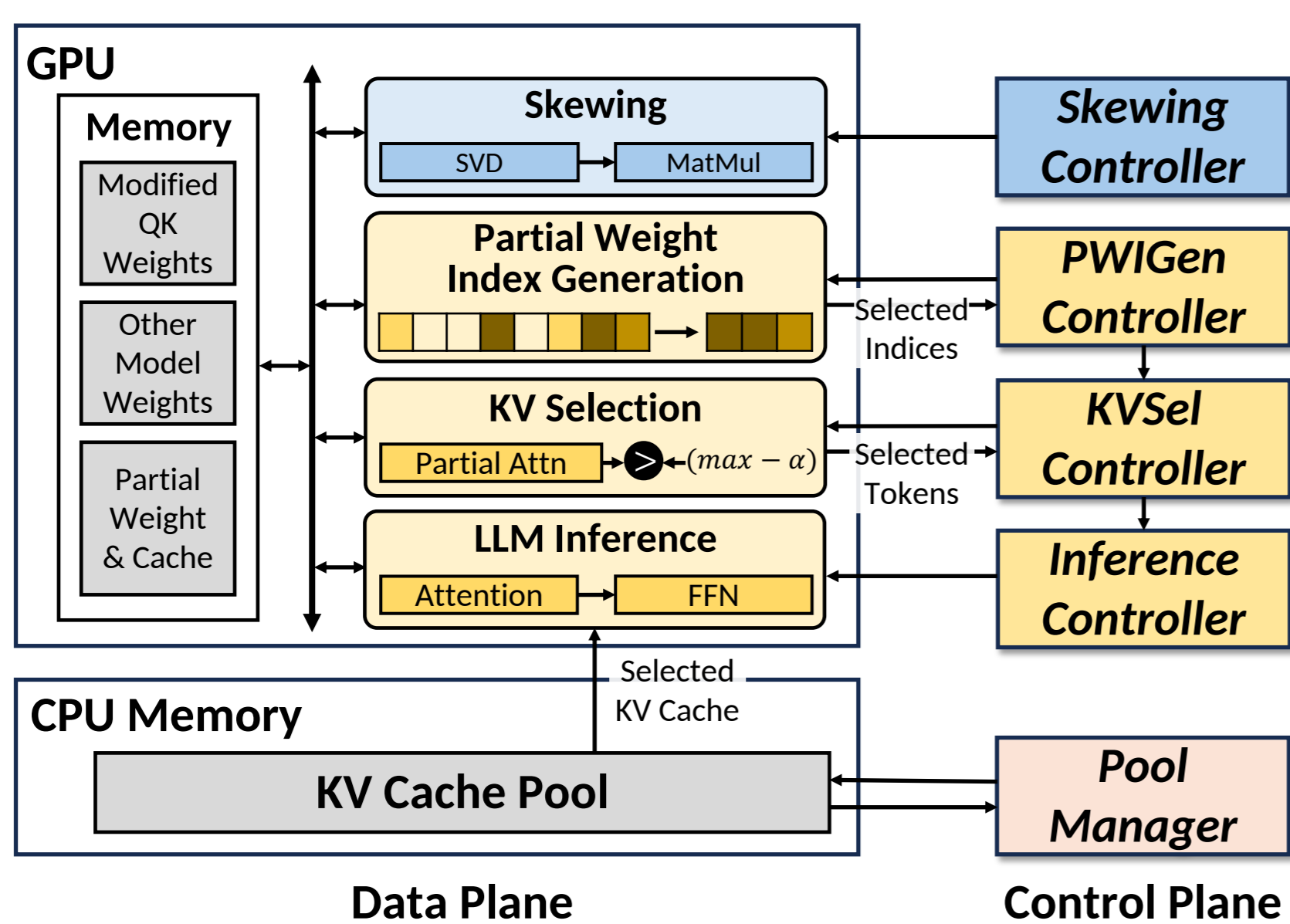

- (Offline) Modify model weights in **Skewing Controller**
- Speculate and prefetch KV tokens in **PWIGen/KV Sel Controller**
- Manage KV cache pool on CPU memory in **Pool Manager**

Efficient KV Cache Prefetching

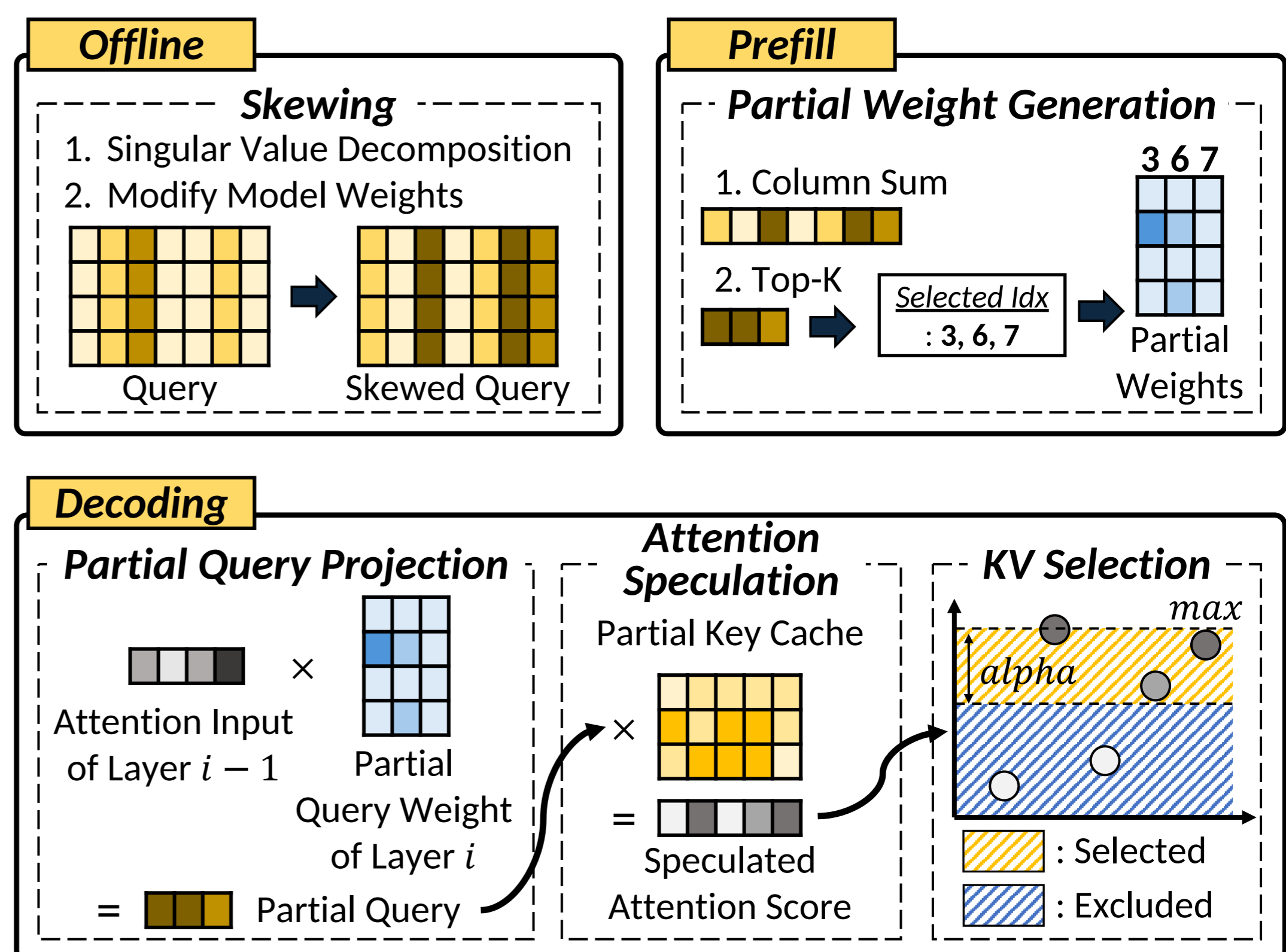

Results

Speedup over Modern Offloading-based Inference System

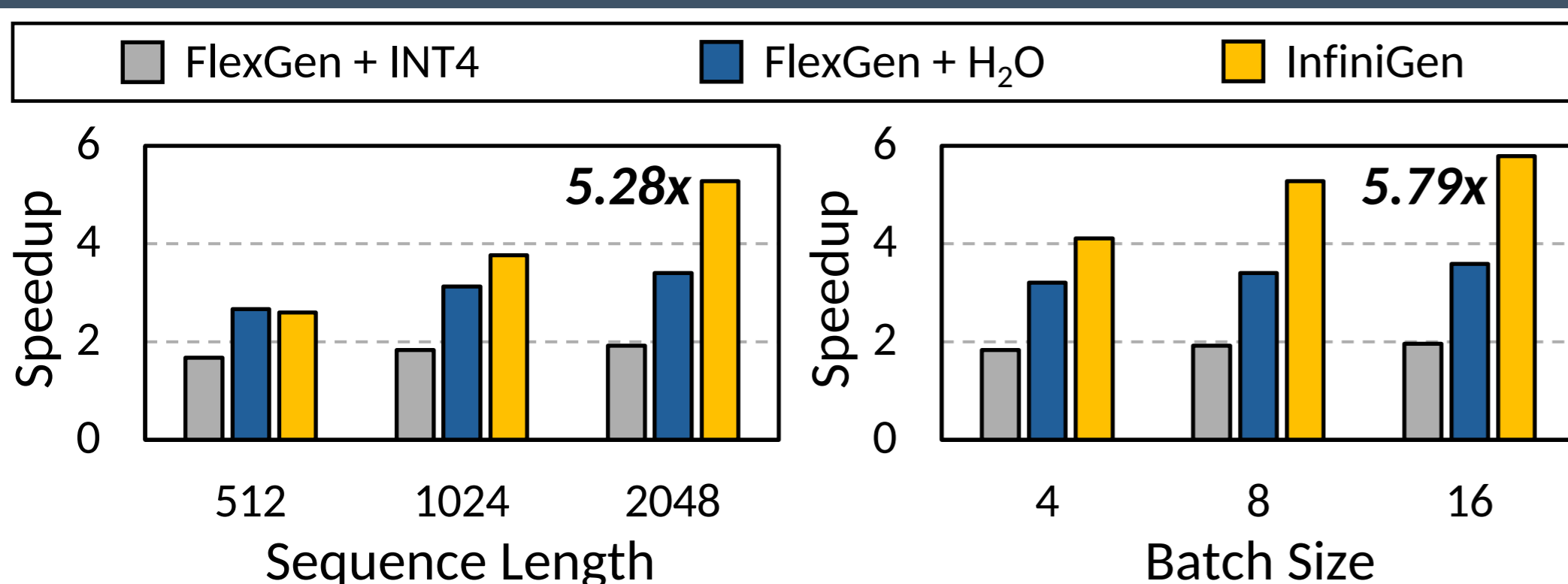

→ **InfiniGen shows a shorter inference latency!**

Accuracy

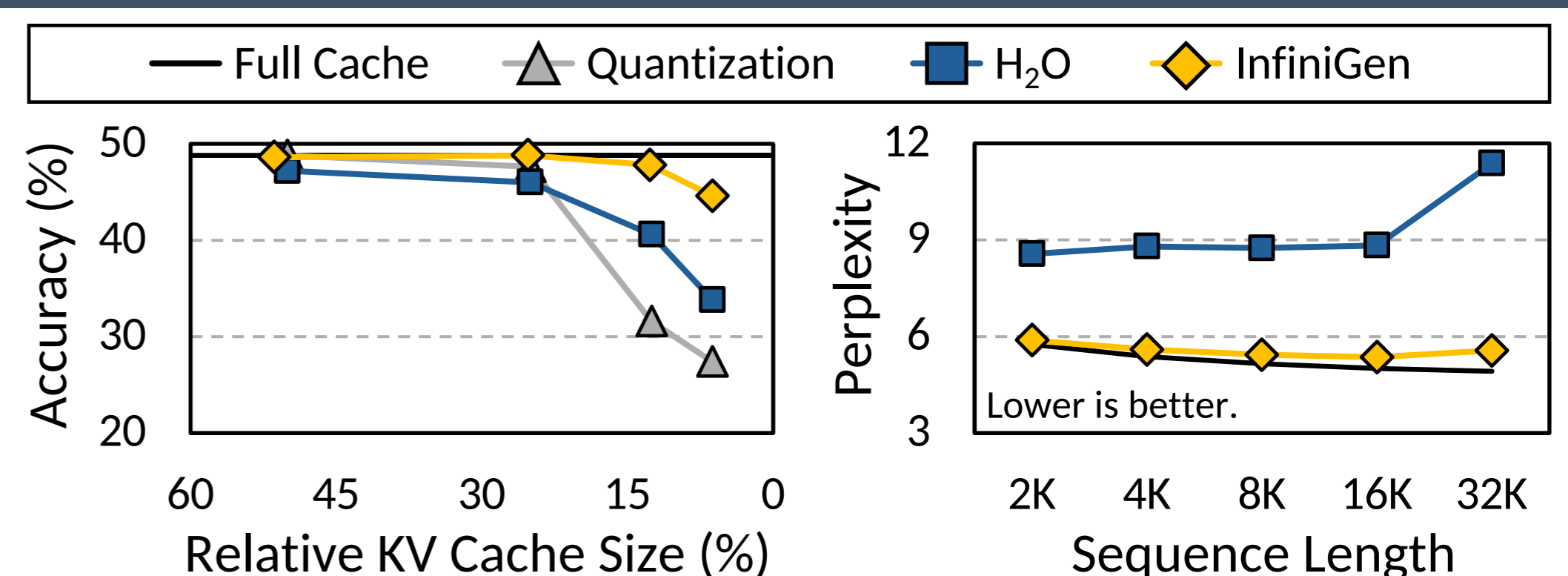

→ **InfiniGen consistently offers better accuracy!**